

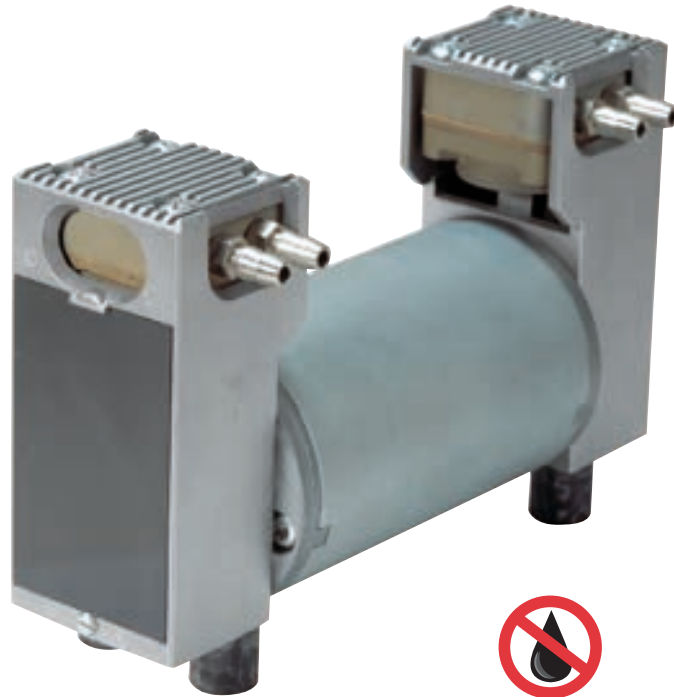

WOB-L™ Piston Air Compressors and Vacuum Pumps

MODELS

8003
8005
8006
8009



OIL-LESS

FEATURES

- Service free and oil-less
- Compact design
- Balanced for smooth, low vibration operation
- Suitable for continuous running
- Wetted parts
 - Series 8003/8005/8006
heat resistant high performance plastic,
Elastomer valves
 - Series 8009
corrosion resistant aluminium parts,
stainless steel valves
 - Long-life, high performance piston seal (PTFE compound)

TYPICAL APPLICATIONS

- Medical industry
- Laboratory and Analysis technology
- Automotive
- Equipment manufacturing

Consult factory for customized solutions



THOMAS
by Gardner Denver

WOB-L Piston Compressor 8003D DC

Flow	3,0 l/min
Max. pressure	2,0 bar

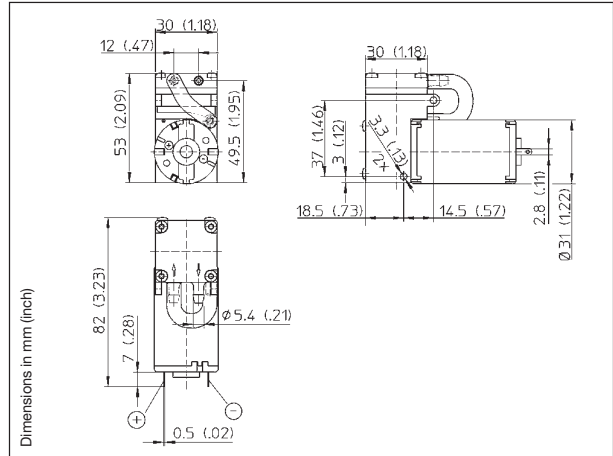
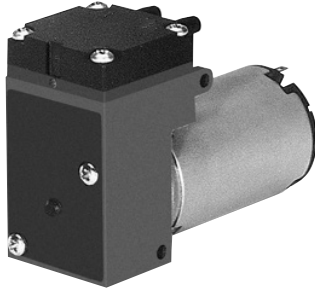

Pneumatic Data		
Description	8003D/22/1,2/E/DC	8003D/24/1,2/E/DC
	12 V DC 24 V DC	80030054 80030057
		80030055 80030058
Max. flow	2,5 l/min	3,0 l/min
Max. pressure	2,0 bar	2,0 bar
Max. continuous pressure	1,0 bar	0,8 bar
Max. restart pressure	1,0 bar	0,8 bar

Electrical Data		
Motor type	Direct current	Direct current
Nominal voltage	12 V/24 V DC	12 V/24 V DC
Nominal speed	3000 rpm	3000 rpm
Power consumption	7,5 W	8,5 W
Motor insulation class	A	A

General Data		
Ambient temperature	10 to 40 °C	10 to 40 °C
Media temperature	10 to 60 °C	10 to 60 °C
Weight	0,19 kg	0,19 kg
Port direction	D	D

All listed values measured at standard atmospheric conditions.

Flow Curves

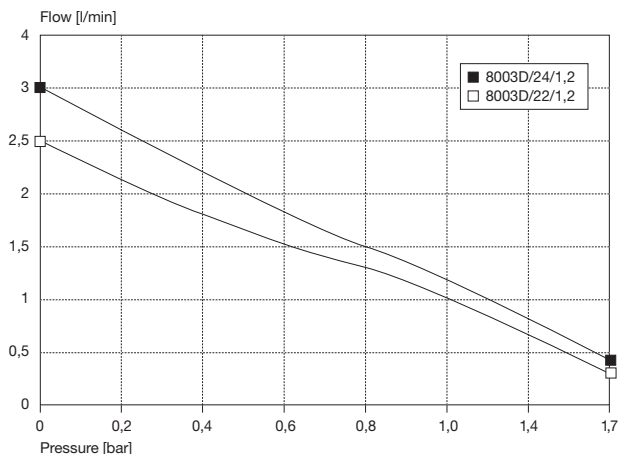

Model key:

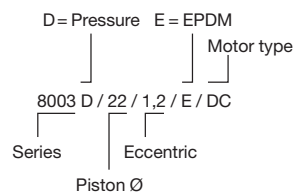

8003... Stock programme

Option:
Low cost DC-motor

The information presented in this material is based on technical data and test results of nominal units. It is believed to be accurate and reliable and is offered as an aid to help in the selection of Thomas products. It is the responsibility of the user to determine the suitability of the product for the intended use and the user assumes all risk and liability whatsoever in connection therewith. Thomas does not warrant, guarantee or assume any obligation or liability in connection with this information.

THOMAS
by Gardner Denver

WOB-L Piston Compressor 8003D BLDC

Flow	4,3 l/min
Max. pressure	2,0 bar

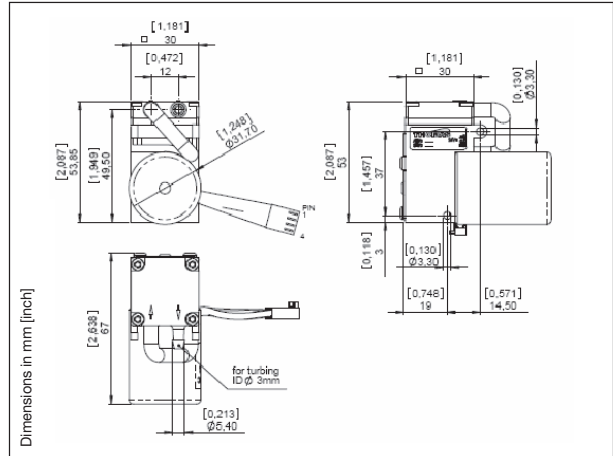

Pneumatic Data

Description	8003D/24/1,2/E/BLDC	
Part number	12 V DC	80030802
	24 V DC	80030803
Max. flow	4,3 l/min	
Max. pressure	2,0 bar	
Max. continuous pressure	1,0 bar	
Max. restart pressure	2,0 bar	

Electrical Data

Motor type	Brushless DC	
Nominal speed	0..4.600 rpm	
Nominal voltage	12/24 V DC	
Drive electronics	integrated with reverse supply voltage protection	
Max. power consumption	8,5 W	
Motor insulation class	B	
Protection class	IP20	
Connector	Housing:	Molex KK 22-01-2045
	Terminal:	Molex KK 08-50-0031

Wiring diagram

Optional: Adapter for 2-wire duty incl. potentiometer for speed adjustment

	Function	Colour	Control
Pin 1	V Supply	Red	12 VDC (max. voltage range: 10..18 VDC) 24 VDC (max. voltage range: 10..28 VDC)
Pin 2	Ground	Black	Ground for Vsupply (PIN 1) and Speed Control (PIN3)
Pin 3	Speed control	White	analog: 0..5 VDC (max. 28V) PWM: 6..20 kHz - 14..96% Speed voltage input threshold: 0,2 V
Pin 4	Tacho out	Green	18 pulses per revolution Pulse time „LOW“: 195 µs Output level „LOW“: 0 / max. 0,5 V Output level „HIGH“: min. 4 V / max. 5 V

General Data

Ambient temperature	15..40°C
Media temperature	15..40°C
Weight	160 g
Port direction	D

Flow Curves vs. Speed Control Input

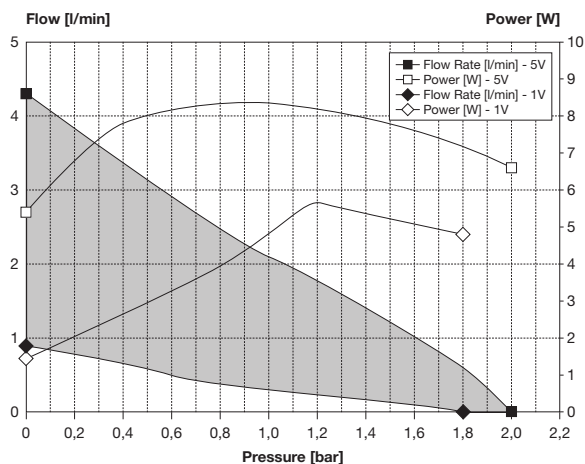

Wetted Parts

Pump head	PAA (IXEF)
Cylinder sleeve	PPS
Piston sealing	PTFE
Valves	EPDM

Model key:

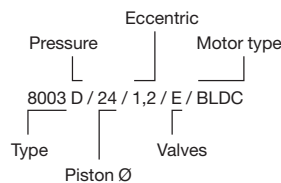

The information presented in this material is based on technical data and test results of nominal units. It is believed to be accurate and reliable and is offered as an aid to help in the selection of Thomas products. It is the responsibility of the user to determine the suitability of the product for the intended use and the user assumes all risk and liability whatsoever in connection therewith. Thomas does not warrant, guarantee or assume any obligation or liability in connection with this information.

THOMAS
by Gardner Denver

WOB-L Piston Compressor 8003ZDP DC

Flow	5,4 l/min
Max. pressure	2,0 bar

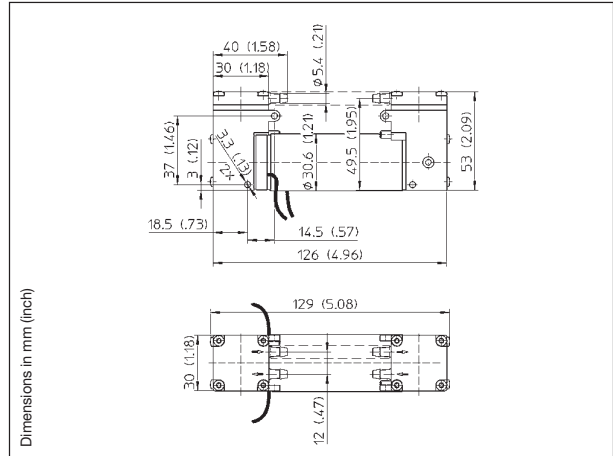
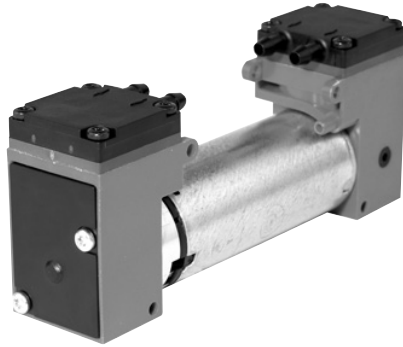

Pneumatic Data

Description	8003ZDP/24/1,2/E/DC	
Part number	12 V DC	80030300
Max. flow	5,4 l/min	
Max. pressure	2,0 bar	
Max. continuous pressure	0,3 bar	
Max. restart pressure	0,5 bar	

Electrical Data

Motor type	Direct current	
Nominal voltage	12 V DC	
Nominal speed	2800 rpm	
Power consumption	13 W	
Motor insulation class	E	

General Data

Ambient temperature	10 to 40 °C	
Media temperature	10 to 60 °C	
Weight	0,35 kg	
Port direction	CB	
Configuration	Parallel	

All listed values measured at standard atmospheric conditions.

Flow Curves

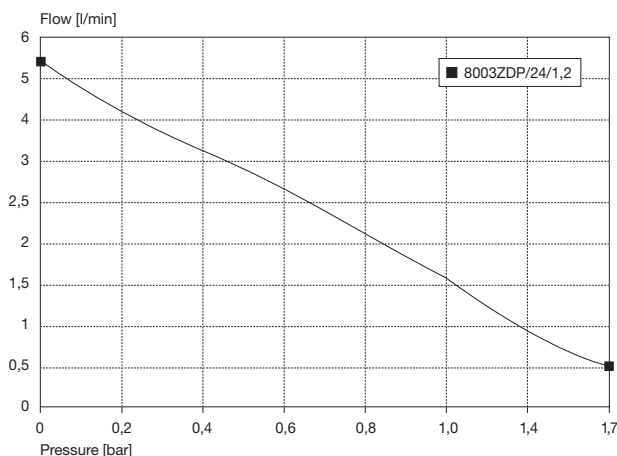

Model key:

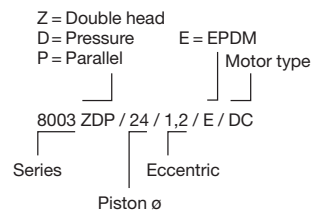

The information presented in this material is based on technical data and test results of nominal units. It is believed to be accurate and reliable and is offered as an aid to help in the selection of Thomas products. It is the responsibility of the user to determine the suitability of the product for the intended use and the user assumes all risk and liability whatsoever in connection therewith. Thomas does not warrant, guarantee or assume any obligation or liability in connection with this information.

THOMAS
by Gardner Denver

WOB-L Piston Vacuum Pump 8003V DC

Flow	3,0 l/min
Max. vacuum	59 %

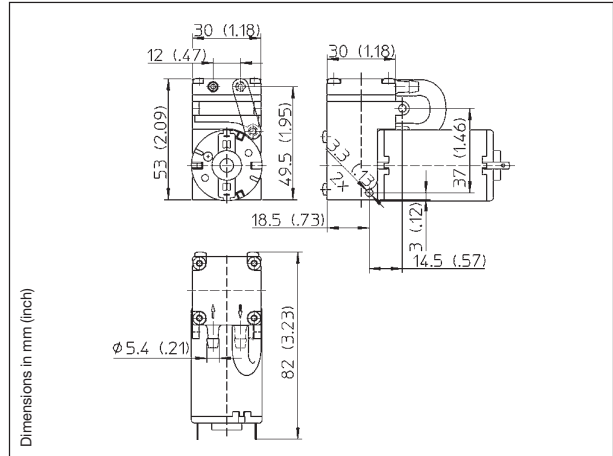
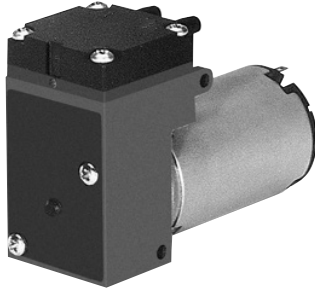

Pneumatic Data

Description	8003V/22/1,2/E/DC	8003V/24/1,2/E/DC
	12 V DC	80030067
	24 V DC	80030071
Max. flow	2,5 l/min	3,0 l/min
Max. vacuum	58 %	59 %
Max. restart vacuum	58 %	59 %

Electrical Data

Motor type	Direct current	Direct current
Nominal voltage	12 V/24 V DC	12 V/24 V DC
Nominal speed	3000 rpm	3000 rpm
Power consumption	5,5 W	6 W
Motor insulation class	A	A

General Data

Ambient temperature	10 to 40 °C	10 to 40 °C
Media temperature	10 to 60 °C	10 to 60 °C
Weight	0,19 kg	0,19 kg
Port direction	D	D

All listed values measured at standard atmospheric conditions.

Flow Curves

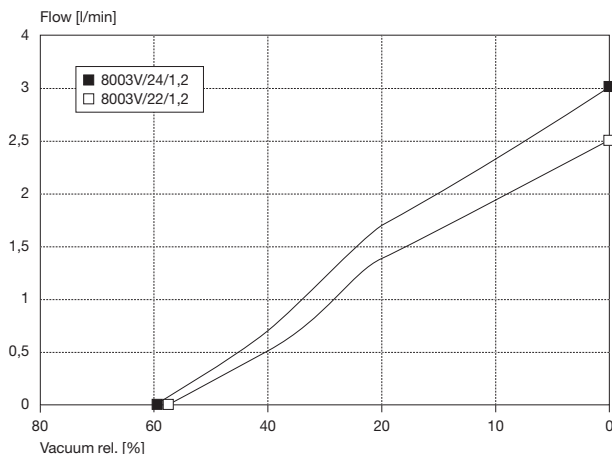

Model key:

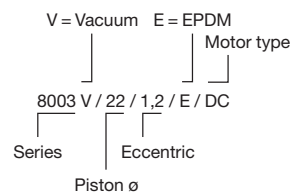

8003... Stock programme

Option:
Low cost DC-motor

The information presented in this material is based on technical data and test results of nominal units. It is believed to be accurate and reliable and is offered as an aid to help in the selection of Thomas products. It is the responsibility of the user to determine the suitability of the product for the intended use and the user assumes all risk and liability whatsoever in connection therewith. Thomas does not warrant, guarantee or assume any obligation or liability in connection with this information.

THOMAS
by Gardner Denver

WOB-L Piston Vacuum Pump 8003V BLDC

Flow	4,3 l/min
Final Vacuum	65 %

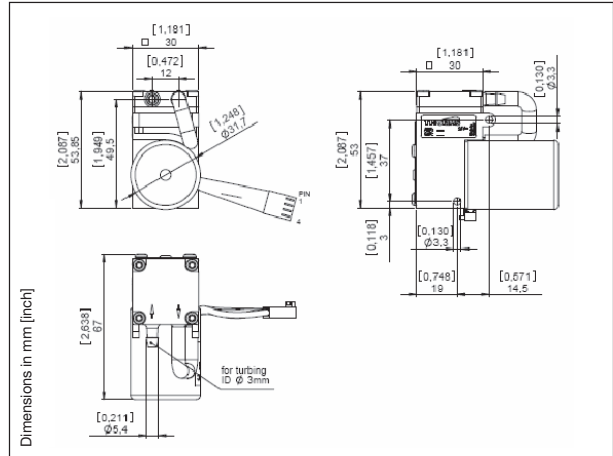

Pneumatic Data

Description	8003V/24/1,2/E/BLDC	
Part number	12 V DC	80030800
	24 V DC	80030801
Max. flow	4,3 l/min	
Max. intermittent vacuum	65 %	
Max. continuous vacuum	65 %	
Max. restart vacuum	65 %	

Electrical Data

Motor type	Brushless DC	
Nominal speed	0..4.600 rpm	
Nominal voltage	12/24 V DC	
Drive electronics	integrated with reverse supply voltage protection	
Max. power consumption	7 W	
Motor insulation class	B	
Protection class	IP20	
Connector	Housing:	Molex KK 22-01-2045
	Terminal:	Molex KK 08-50-0031

Wiring diagram

Optional: Adapter for 2-wire duty incl. potentiometer for speed adjustment

	Function	Colour	Control
Pin 1	V Supply	Red	12 VDC (max. voltage range: 10..18 VDC) 24 VDC (max. voltage range: 10..28 VDC)
Pin 2	Ground	Black	Ground for Vsupply (PIN 1) and Speed Control (PIN3)
Pin 3	Speed control	White	analog: 0..5 VDC (max. 28V) PWM: 6..20 kHz - 14..96% Speed voltage input threshold: 0,2 V
Pin 4	Tacho out	Green	18 pulses per revolution Pulse time „LOW“: 195 µs Output level „LOW“: 0 / max. 0,5 V Output level „HIGH“: min. 4 V / max. 5 V

General Data

Ambient temperature	15..40°C
Media temperature	15..40°C
Weight	160 g
Port direction	D

Flow Curves vs. Speed Control Input

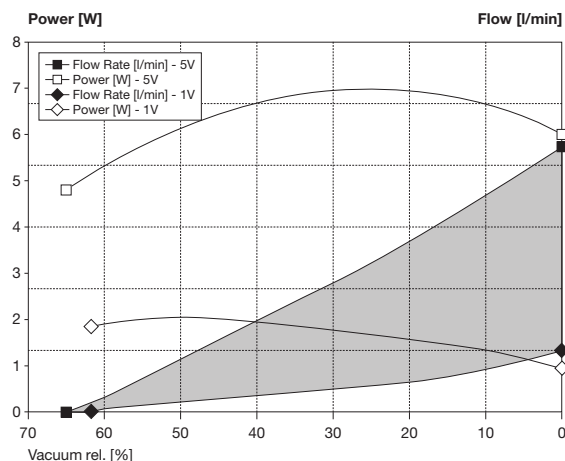

Wetted Parts

Pump head	PAA (IXEF)
Cylinder sleeve	PPS
Piston sealing	PTFE
Valves	EPDM

Model key:

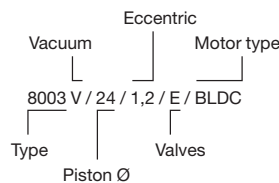

The information presented in this material is based on technical data and test results of nominal units. It is believed to be accurate and reliable and is offered as an aid to help in the selection of Thomas products. It is the responsibility of the user to determine the suitability of the product for the intended use and the user assumes all risk and liability whatsoever in connection therewith. Thomas does not warrant, guarantee or assume any obligation or liability in connection with this information.



WOB-L Piston Vacuum Pump 8003ZVR/ZVP DC

Flow	5,4 l/min
Max. vacuum	80 %

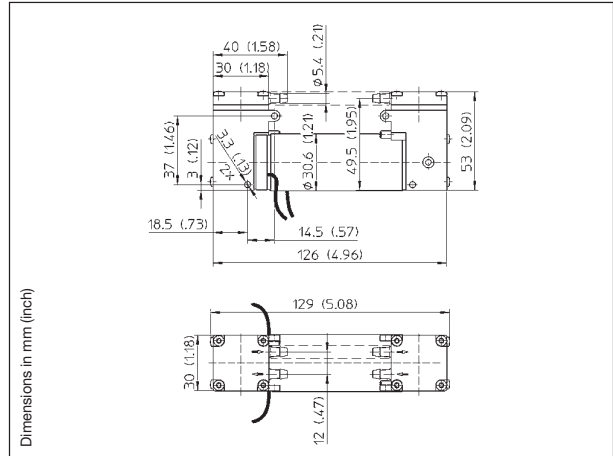
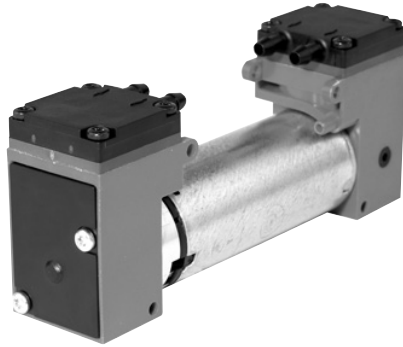

Pneumatic Data

Description	8003ZVR/24/1,2/E/DC	8003ZVP/24/1,2/E/DC
Part number	80030321	80030320
Max. flow	2,9 l/min	5,4 l/min
Max. vacuum	80 %	59 %
Max. restart vacuum	80 %	59 %

Electrical Data

Motor type	Direct current	Direct current
Nominal voltage	12 V DC	12 V DC
Nominal speed	2800 rpm	2800 rpm
Power consumption	11 W	11 W
Motor insulation class	E	E

General Data

Ambient temperature	10 to 40 °C	10 to 40 °C
Media temperature	10 to 60 °C	10 to 60 °C
Weight	0,35 kg	0,35 kg
Port direction	DD	CB
Configuration	Series	Parallel

All listed values measured at standard atmospheric conditions.

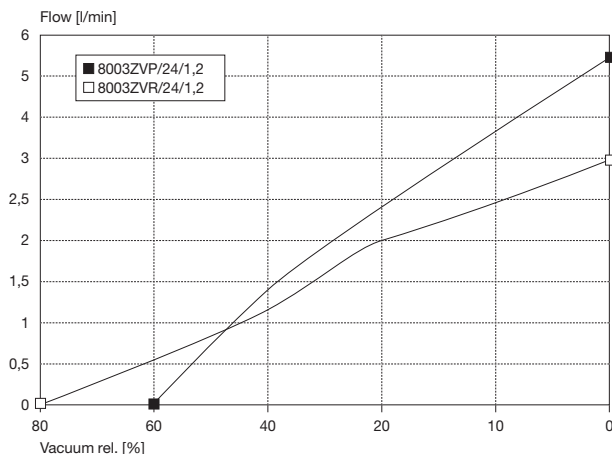

Model key:

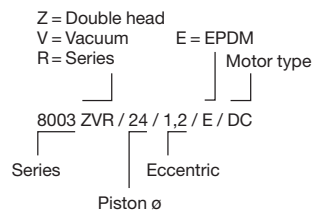

The information presented in this material is based on technical data and test results of nominal units. It is believed to be accurate and reliable and is offered as an aid to help in the selection of Thomas products. It is the responsibility of the user to determine the suitability of the product for the intended use and the user assumes all risk and liability whatsoever in connection therewith. Thomas does not warrant, guarantee or assume any obligation or liability in connection with this information.

THOMAS
by Gardner Denver

WOB-L Piston Compressor 8005D DC

Flow	7,2 l/min
Max. pressure	2,5 bar

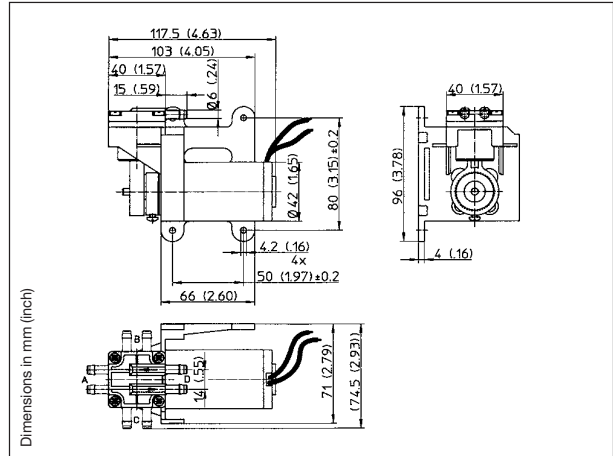
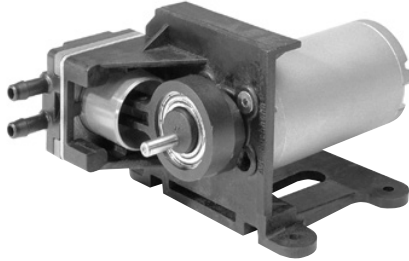

Pneumatic Data

Description	8005D/20/4,0/V/DC	8005D/22/4,0/V/DC
Part number	80050062	80050077
	12 V DC	24 V DC*
	80050064	80050079
Max. flow	5,8 l/min	7,2 l/min
Max. pressure	2,5 bar	2,5 bar
Max. continuous pressure	1,5 bar	1,5 bar
Max. restart pressure	2,5 bar	2,3 bar

Electrical Data

Motor type	Direct current	Direct current
Nominal voltage	12 V/24 V DC	12 V/24 V DC
Nominal speed	3500/3200 rpm	3500/3200 rpm
Power consumption	26 W	32 W
Motor insulation class	E	E

General Data

Ambient temperature	10 to 40 °C	10 to 40 °C
Media temperature	10 to 60 °C	10 to 60 °C
Weight	1,1 kg	1,1 kg
Port direction	D	D

* Due to a difference in nominal speeds the 24 V DC units have a 10% reduced flow rate when compared to the 12 V DC units.
All listed values measured at standard atmospheric conditions.

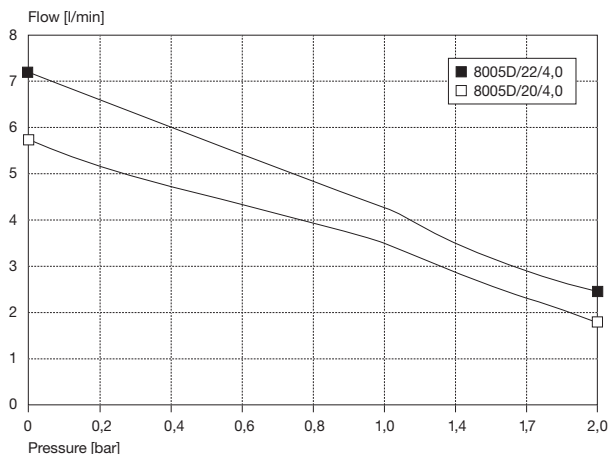

Model key:

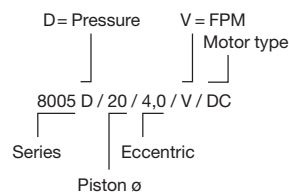

Option:
Noise reduced head
Brushless DC-motor

The information presented in this material is based on technical data and test results of nominal units. It is believed to be accurate and reliable and is offered as an aid to help in the selection of Thomas products. It is the responsibility of the user to determine the suitability of the product for the intended use and the user assumes all risk and liability whatsoever in connection therewith. Thomas does not warrant, guarantee or assume any obligation or liability in connection with this information.

THOMAS
by Gardner Denver

WOB-L Piston Compressor 8005D AC

Flow	6,0 l/min
Max. pressure	2,5 bar

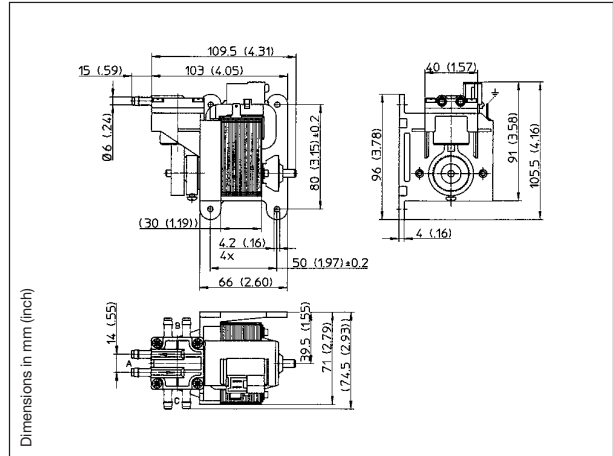
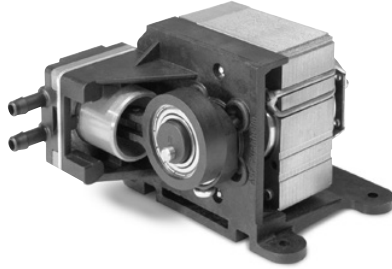

Pneumatic Data

Description	8005D/20/4,0V/AC	8005D/22/4,0V/AC
Part number	230 V/50 Hz 80050063	80050078
Max. flow	4,8 l/min	6,0 l/min
Max. pressure	2,5 bar	2,5 bar
Max. continuous pressure	1,5 bar	1,5 bar
Max. restart pressure	0,5 bar	0,4 bar

Electrical Data

Motor type	Shaded pole	Shaded pole
Nominal voltage	230 V/50 Hz	230 V/50 Hz
Nominal speed	2400 rpm	2400 rpm
Power consumption	135 W	135 W
Motor insulation class	F	F
Thermal switch	115 °C	115 °C

General Data

Ambient temperature	10 to 40 °C	10 to 40 °C
Media temperature	10 to 40 °C	10 to 40 °C
Weight	1,1 kg	1,1 kg
Port direction	A	A

All listed values measured at standard atmospheric conditions.

Flow Curves

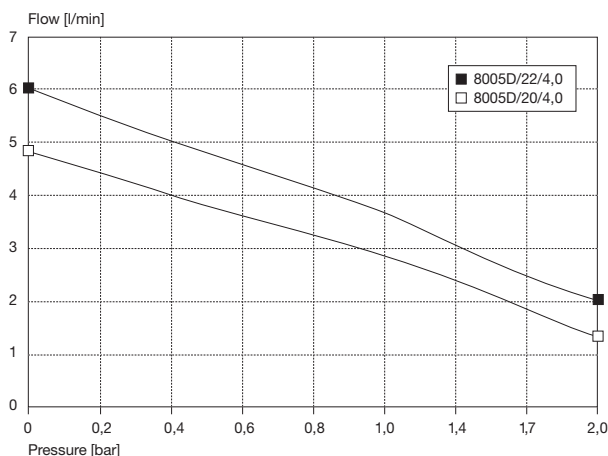

Model key:

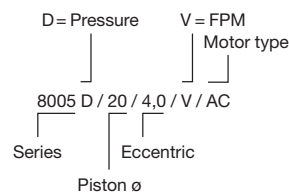

The information presented in this material is based on technical data and test results of nominal units. It is believed to be accurate and reliable and is offered as an aid to help in the selection of Thomas products. It is the responsibility of the user to determine the suitability of the product for the intended use and the user assumes all risk and liability whatsoever in connection therewith. Thomas does not warrant, guarantee or assume any obligation or liability in connection with this information.

THOMAS
by Gardner Denver

WOB-L Piston Vacuum Pump 8005V DC

Flow	7,2 l/min
Max. vacuum	78 %

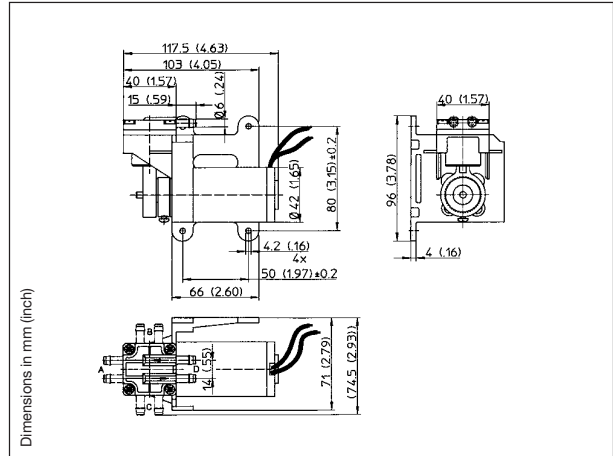
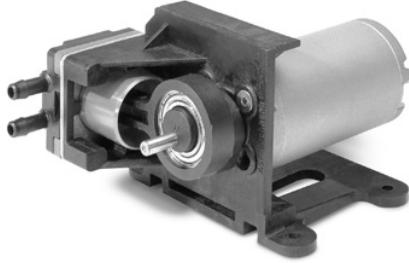

Pneumatic Data

Description	8005V/20/4,0V/DC	8005V/22/4,0V/DC
Part number	12 V DC 80050034 24 V DC* 80050044	80050039 80050049
Max. flow	5,8 l/min	7,2 l/min
Max. vacuum	73 %	78 %
Max. restart vacuum	73 %	78 %

Electrical Data

Motor type	Direct current	Direct current
Nominal voltage	12 V/24 V DC	12 V/24 V DC
Nominal speed	3500/3250 rpm	3500/3250 rpm
Power consumption	22 W	26 W
Motor insulation class	E	E

General Data

Ambient temperature	10 to 40 °C	10 to 40 °C
Media temperature	10 to 60 °C	10 to 60 °C
Weight	1,1 kg	1,1 kg
Port direction	D	D

* Due to a difference in nominal speeds the 24 V DC units have a 10 % reduced flow rate when compared to the 12 V DC units.
All listed values measured at standard atmospheric conditions.

Flow Curves

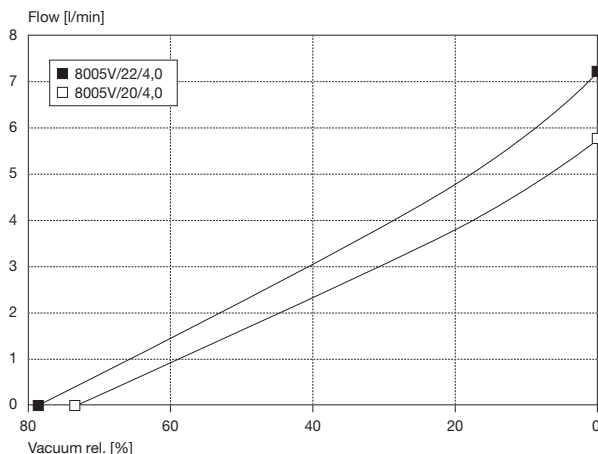

Model key:

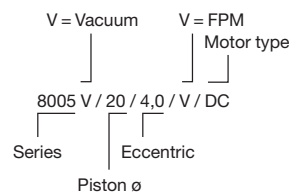

Option:
Noise reduced head
Brushless DC-motor

The information presented in this material is based on technical data and test results of nominal units. It is believed to be accurate and reliable and is offered as an aid to help in the selection of Thomas products. It is the responsibility of the user to determine the suitability of the product for the intended use and the user assumes all risk and liability whatsoever in connection therewith. Thomas does not warrant, guarantee or assume any obligation or liability in connection with this information.

THOMAS
by Gardner Denver

WOB-L Piston Compressor 8006D DC

Flow	15,8 l/min
Max. pressure	3,0 bar

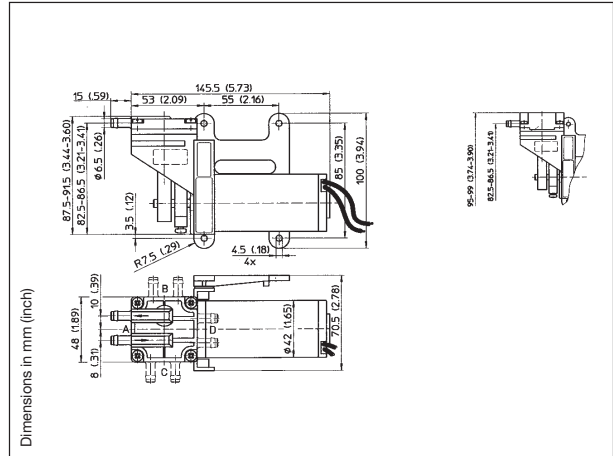
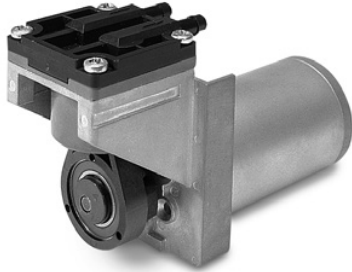

Pneumatic Data		
Description	8006D/27/4,5/V/DC	8006D/30/4,5/V/DC
Part number	12 V DC 80060057 24 V DC 80060110	80060071 80060079
Max. flow	13,0 l/min	15,8 l/min
Max. pressure	3,0 bar	3,0 bar
Max. continuous pressure	1,0 bar	1,0 bar
Max. restart pressure	1,0 bar	0,4 bar

Electrical Data		
Motor type	Direct current	Direct current
Nominal voltage	12 V/24 V DC	12 V/24 V DC
Nominal speed	2800 rpm	2800 rpm
Power consumption	40 W	46 W
Motor insulation class	E	E

General Data		
Ambient temperature	10 to 40 °C	10 to 40 °C
Media temperature	10 to 60 °C	10 to 60 °C
Weight	1,2 kg	1,2 kg
Port direction	D	D

All listed values measured at standard atmospheric conditions.

Flow Curves

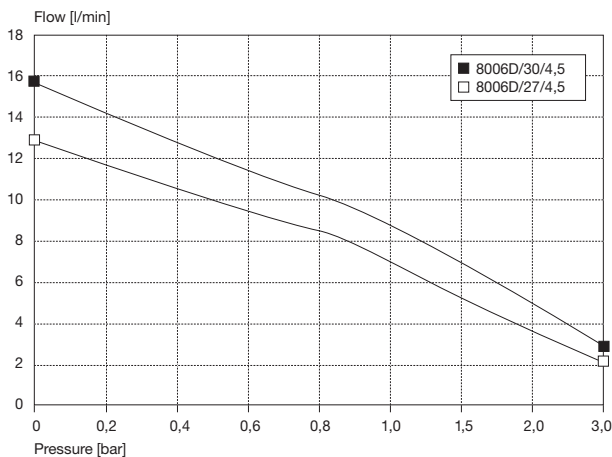

Model key:

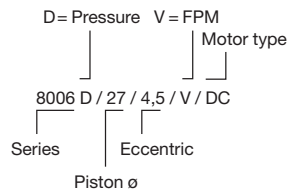

8006... Stock programme

Option:
 Noise reduced head
 Brushless DC-motor
 Con rod cover

The information presented in this material is based on technical data and test results of nominal units. It is believed to be accurate and reliable and is offered as an aid to help in the selection of Thomas products. It is the responsibility of the user to determine the suitability of the product for the intended use and the user assumes all risk and liability whatsoever in connection therewith. Thomas does not warrant, guarantee or assume any obligation or liability in connection with this information.

THOMAS
 by Gardner Denver

WOB-L Piston Compressor 8006D AC

Flow	15,8 l/min
Max. pressure	3,0 bar

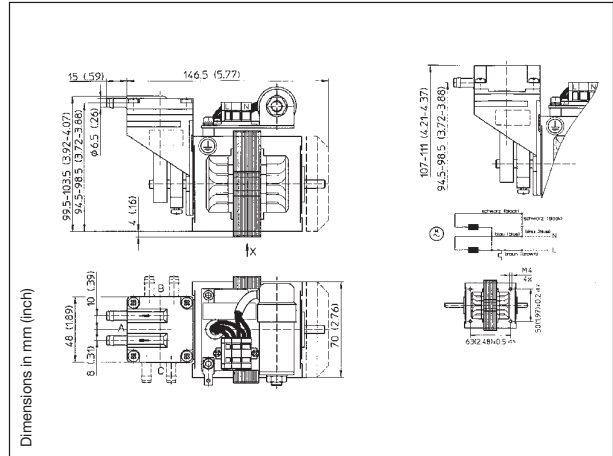
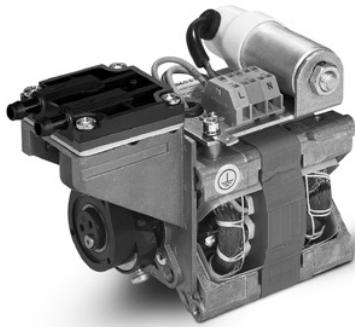

Pneumatic Data

Description	8006D/27/3,5/V/AC	8006D/27/4,5/V/AC	8006D/30/4,5/V/AC
Part number	230 V/50 Hz 80060096	80060098	80060007
Max. flow	10,1 l/min	13,0 l/min	15,8 l/min
Max. pressure	3,0 bar	3,0 bar	3,0 bar
Max. continuous pressure	1,5 bar	1,2 bar	1,0 bar
Max. restart pressure	Ambient pressure	Ambient pressure	Ambient pressure

Electrical Data

Motor type	Capacitor	Capacitor	Capacitor
Nominal voltage	230 V/50 Hz	230 V/50 Hz	230 V/50 Hz
Nominal speed	2800 rpm	2800 rpm	2800 rpm
Power consumption	80 W	80 W	80 W
Motor insulation class	F	F	F
Thermal switch	150° C	150° C	150° C

General Data

Ambient temperature	10 to 40 °C	10 to 40 °C	10 to 40 °C
Media temperature	10 to 40 °C	10 to 40 °C	10 to 40 °C
Weight	1,5 kg	1,5 kg	1,5 kg
Port direction	A	A	A

All listed values measured at standard atmospheric conditions.

Flow Curves

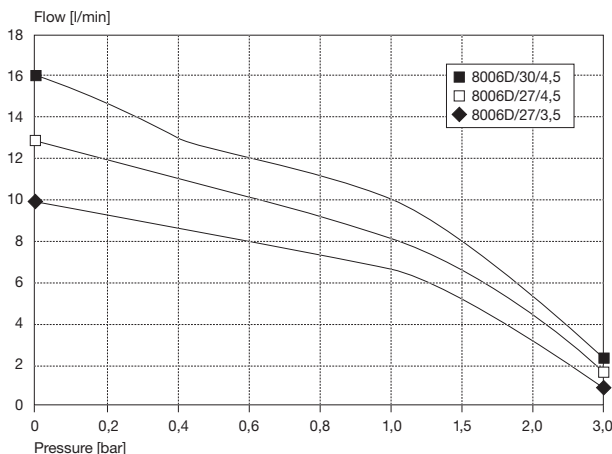

Model key:

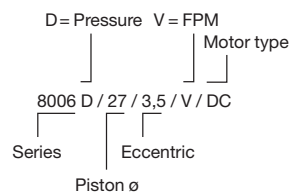

Option:
Noise reduced head
Con rod cover

The information presented in this material is based on technical data and test results of nominal units. It is believed to be accurate and reliable and is offered as an aid to help in the selection of Thomas products. It is the responsibility of the user to determine the suitability of the product for the intended use and the user assumes all risk and liability whatsoever in connection therewith. Thomas does not warrant, guarantee or assume any obligation or liability in connection with this information.

THOMAS
by Gardner Denver

WOB-L Piston Vacuum Pump 8006ZV DC

Flow	31,0 l/min
Max. vacuum	80 %

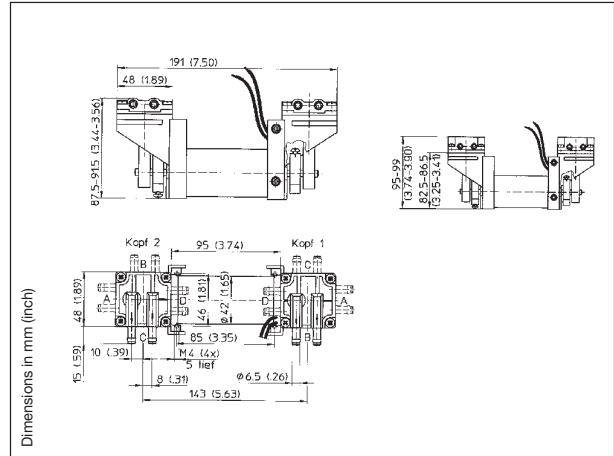
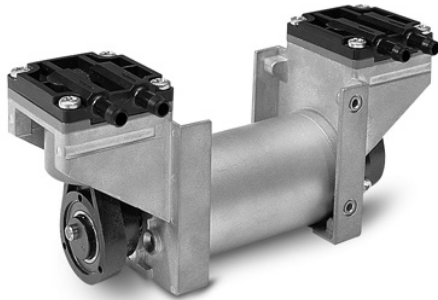

Pneumatic Data

Description	8006ZV/30/4,5V/DC	
Part number	12 V DC	80060131
	24 V DC	80060135
Max. flow	31,0 l/min	
Max. vacuum	80 %	
Max. restart vacuum	Ambient pressure	

Electrical Data

Motor type	Direct current
Nominal voltage	12 V/24 V DC
Nominal speed	2800 rpm
Power consumption	60 W
Motor insulation class	E

General Data

Ambient temperature	10 to 40 °C
Media temperature	10 to 60 °C
Weight	0,93 kg
Port direction	CB
Configuration	parallel

All listed values measured at standard atmospheric conditions.
Pneumatic data refer to parallel configuration.

Flow Curves

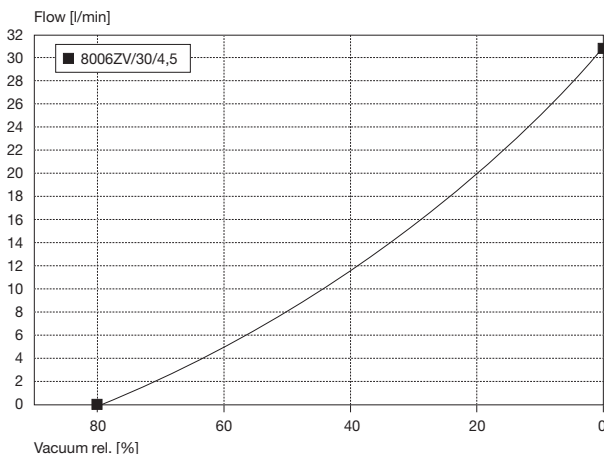

Model key:

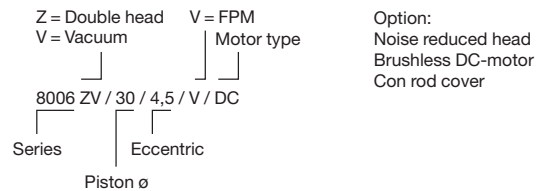

The information presented in this material is based on technical data and test results of nominal units. It is believed to be accurate and reliable and is offered as an aid to help in the selection of Thomas products. It is the responsibility of the user to determine the suitability of the product for the intended use and the user assumes all risk and liability whatsoever in connection therewith. Thomas does not warrant, guarantee or assume any obligation or liability in connection with this information.

THOMAS
by Gardner Denver

WOB-L Piston Vacuum Pump 8006ZV AC

Flow	29,0 l/min
Max. vacuum	95 %

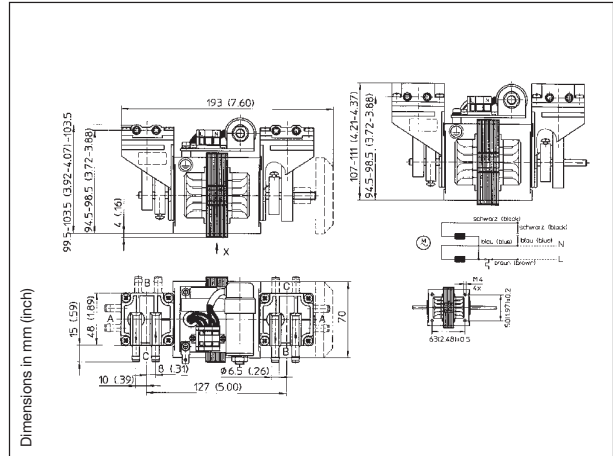
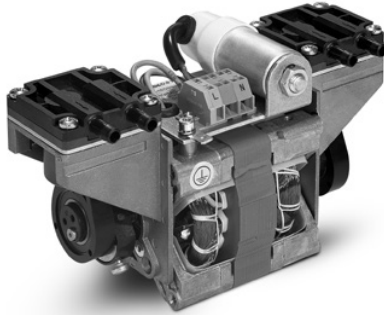

Pneumatic Data

Description	8006ZVR/30/4,5/V/AC	8006ZV/27/4,5/V/AC	8006ZV/30/4,5/V/AC
Part number	230 V/50 Hz 80060442	80060105	80060109
Max. flow	14,2 l/min	23,5 l/min*	29,0 l/min*
Max. vacuum	95 %	78 %*	80 %*
Max. restart vacuum	Ambient pressure	Ambient pressure*	Ambient pressure*

Electrical Data

Motor type	Capacitor	Capacitor	Capacitor
Nominal voltage	230 V/50 Hz	230 V/50 Hz	230 V/50 Hz
Nominal speed	2800 rpm	2800 rpm	2800 rpm
Power consumption	85 W	85 W	85 W
Motor insulation class	F	F	F
Thermal switch	150 °C	150 °C	150 °C

General Data

Ambient temperature	10 to 40 °C	10 to 40 °C	10 to 40 °C
Media temperature	10 to 40 °C	10 to 40 °C	10 to 40 °C
Weight	2,0 kg	2,0 kg	2,0 kg
Port direction	CB	CB	CB
Configuration	series	parallel	parallel

All listed values measured at standard atmospheric conditions.
*Pneumatic data refer to parallel configuration.

Flow Curves

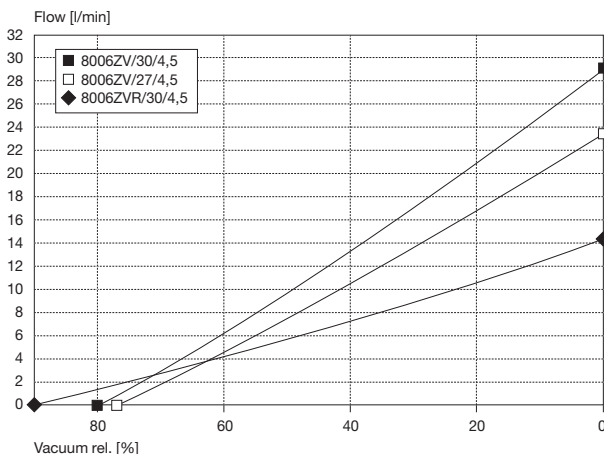

Model key:

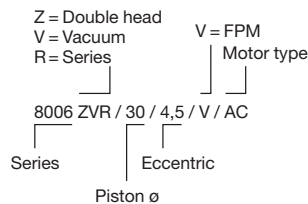

8006... Stock programme

Option:
Noise reduced head
Con rod cover

The information presented in this material is based on technical data and test results of nominal units. It is believed to be accurate and reliable and is offered as an aid to help in the selection of Thomas products. It is the responsibility of the user to determine the suitability of the product for the intended use and the user assumes all risk and liability whatsoever in connection therewith. Thomas does not warrant, guarantee or assume any obligation or liability in connection with this information.

THOMAS
by Gardner Denver

WOB-L Piston Compressor 8009D DC

Flow	14,0 l/min
Max. pressure	7,0 bar

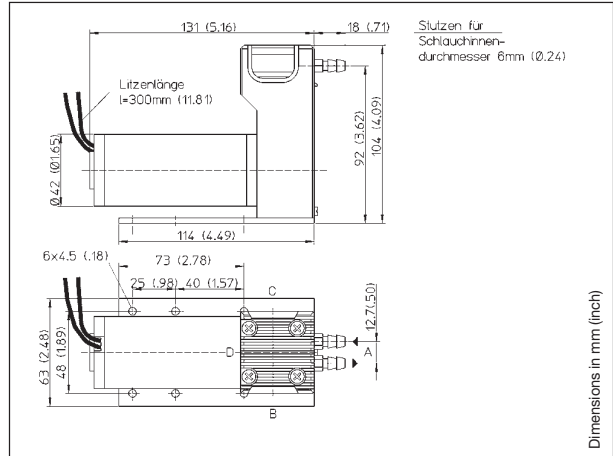

Pneumatic Data				
Description		8009-30/10/DC	8009-35/05/DC	8009-40/00/DC
Part number	12 V DC	80091019	80091020	80091021
	24 V DC	80091031	80091032	80091033
Max. flow		11,0 l/min	12,5 l/min	14,0 l/min
Max. pressure		7,0 bar	7,0 bar	7,0 bar
Max. continuous pressure		1,5 bar	1,2 bar	1,0 bar
Max. restart pressure		0,8 bar	0,6 bar	0,5 bar

Electrical Data				
Motor type		Direct current	Direct current	Direct current
Nominal voltage		12 V/24 V DC	12 V/24 V DC	12 V/24 V DC
Nominal speed		2800 rpm	2800 rpm	2800 rpm
Power consumption		50 W	58 W	65 W
Motor insulation class		E	E	E

General Data				
Ambient temperature		10 to 40 °C	10 to 40 °C	10 to 40 °C
Media temperature		10 to 60 °C	10 to 60 °C	10 to 60 °C
Weight		1,1 kg	1,1 kg	1,1 kg
Port direction		A	A	A

All listed values measured at standard atmospheric conditions.

Flow Curves

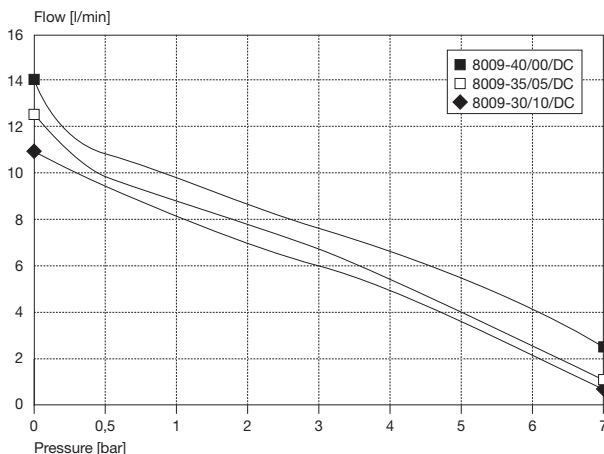

Model key:

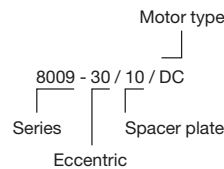

8009... Stock programme

Option:
Different heads and
outlet connectors

The information presented in this material is based on technical data and test results of nominal units. It is believed to be accurate and reliable and is offered as an aid to help in the selection of Thomas products. It is the responsibility of the user to determine the suitability of the product for the intended use and the user assumes all risk and liability whatsoever in connection therewith. Thomas does not warrant, guarantee or assume any obligation or liability in connection with this information.

THOMAS
by Gardner Denver

WOB-L Piston Compressor 8009D AC

Flow	11,8 l/min
Max. pressure	7,0 bar

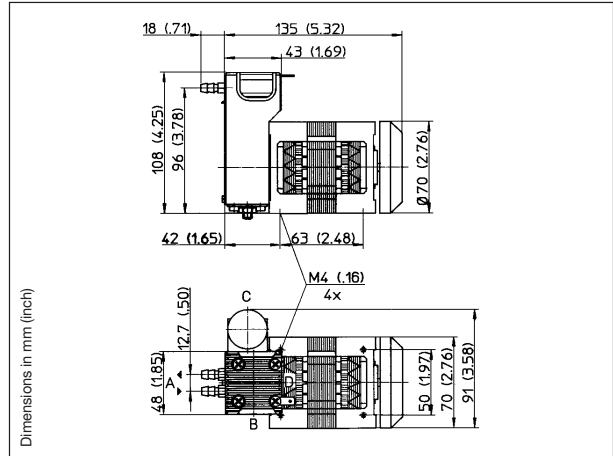
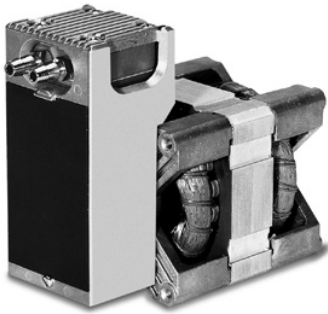

Pneumatic Data

Description	8009-30H/10/AC	8009-35H/05/AC	8009-40H/00/AC
Part number	80091037	80091038	80091039
Max. flow	8,8 l/min	10,3 l/min	11,8 l/min
Max. pressure	6,0 bar	7,0 bar	7,0 bar
Max. continuous pressure	1,8 bar	1,4 bar	1,0 bar
Max. restart pressure	0,5 bar	Ambient pressure	Ambient pressure

Electrical Data

Motor type	Capacitor	Capacitor	Capacitor
Nominal voltage	230 V/50 Hz	230 V/50 Hz	230 V/50 Hz
Nominal speed	2700 rpm	2700 rpm	2700 rpm
Power consumption	78 W	78 W	78 W
Motor insulation class	B	B	B
Thermal switch	130 °C	130 °C	130 °C

General Data

Ambient temperature	10 to 40 °C	10 to 40 °C	10 to 40 °C
Media temperature	10 to 40 °C	10 to 40 °C	10 to 40 °C
Weight	1,7 kg	1,7 kg	1,7 kg
Port direction	A	A	A

All listed values measured at standard atmospheric conditions.

Flow Curves

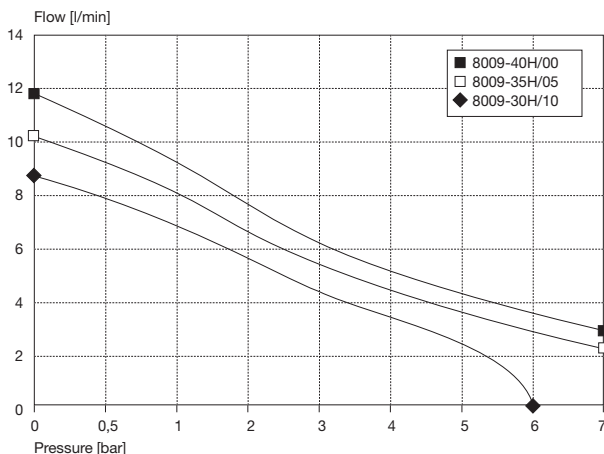

Model key:

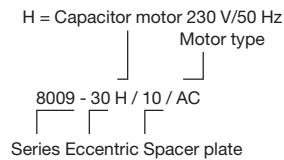

8009... Stock programme

Option:
 Different heads and
 outlet connectors

The information presented in this material is based on technical data and test results of nominal units. It is believed to be accurate and reliable and is offered as an aid to help in the selection of Thomas products. It is the responsibility of the user to determine the suitability of the product for the intended use and the user assumes all risk and liability whatsoever in connection therewith. Thomas does not warrant, guarantee or assume any obligation or liability in connection with this information.

THOMAS
 by Gardner Denver

WOB-L Piston Compressor 8009ZD DC

Flow	24,5 l/min
Max. pressure	7,0 bar

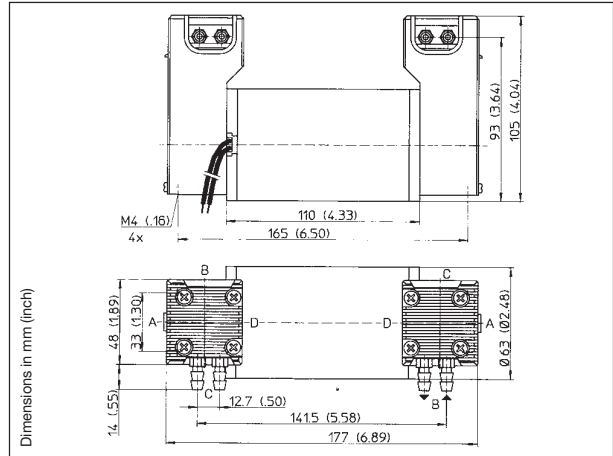
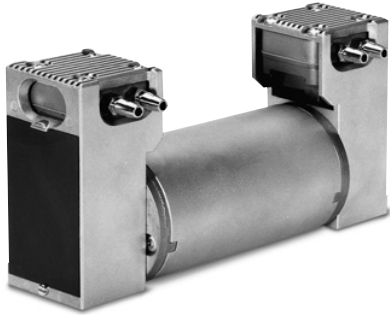

Pneumatic Data

Description	8009Z-35M/05/DC	8009Z-40M/00/DC
Part number	80091066	80091067
24 V DC		
Max. flow	21,4 l/min	24,5 l/min
Max. pressure	7,0 bar	7,0 bar
Max. continuous pressure	1,2 bar	1,0 bar
Max. restart pressure	2,5 bar	2,0 bar

Electrical Data

Motor type	Direct current	Direct current
Nominal voltage	24 V DC	24 V DC
Nominal speed	2900 rpm	2900 rpm
Power consumption	115 W	150 W
Motor insulation class	E	E

General Data

Ambient temperature	10 to 40 °C	10 to 40 °C
Media temperature	10 to 60 °C	10 to 60 °C
Weight	2,1 kg	2,1 kg
Port direction	CB	CB
Configuration	parallel	parallel

All listed values measured at standard atmospheric conditions.
Pneumatic data refer to parallel configuration.

Flow Curves

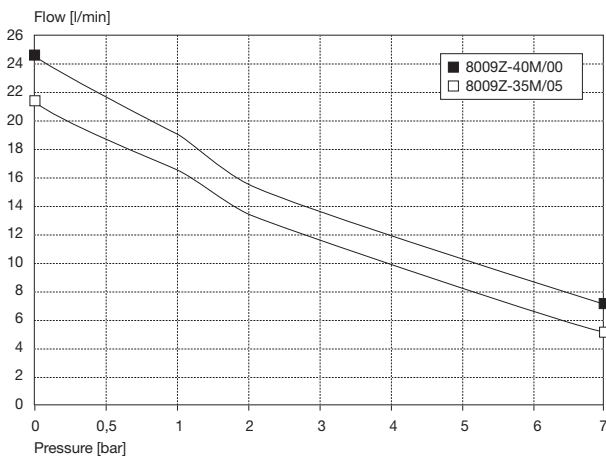

Model key:

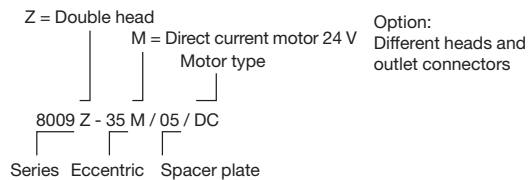

The information presented in this material is based on technical data and test results of nominal units. It is believed to be accurate and reliable and is offered as an aid to help in the selection of Thomas products. It is the responsibility of the user to determine the suitability of the product for the intended use and the user assumes all risk and liability whatsoever in connection therewith. Thomas does not warrant, guarantee or assume any obligation or liability in connection with this information.

THOMAS
by Gardner Denver

WOB-L Piston Compressor 8009ZD AC

Flow	22,4 l/min
Max. pressure	7,0 bar

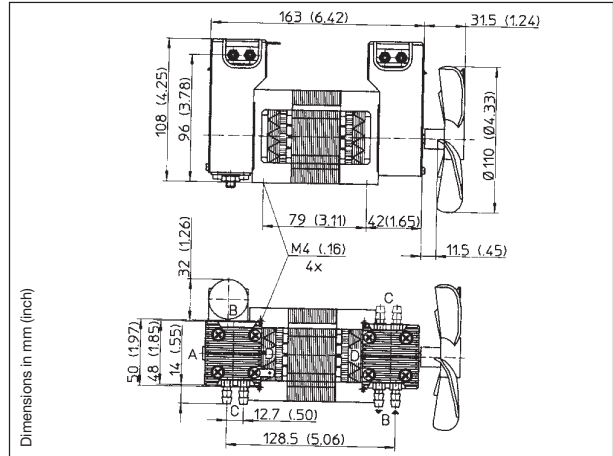
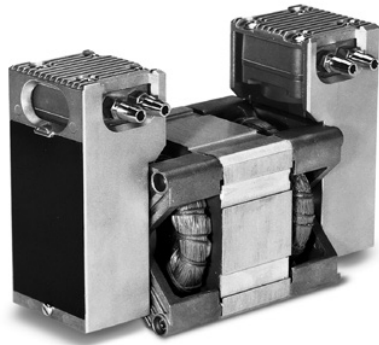

Pneumatic Data

Description	8009Z-35L/05/AC	8009Z-40L/00/AC
Part number	80090378	80090435
Max. flow	19,6 l/min	22,4 l/min
Max. pressure	7,0 bar	7,0 bar
Max. continuous pressure	1,4 bar	1,0 bar
Max. restart pressure	Ambient pressure	Ambient pressure

Electrical Data

Motor type	Capacitor	Capacitor
Nominal voltage	230 V/50 Hz	230 V/50 Hz
Nominal speed	2700 rpm	2700 rpm
Power consumption	138 W	138 W
Motor insulation class	B	B
Thermal switch	130 °C	130 °C

General Data

Ambient temperature	10 to 40 °C	10 to 40 °C
Media temperature	10 to 40 °C	10 to 40 °C
Weight	2,5 kg	2,5 kg
Port direction	CB	CB
Configuration	parallel	parallel

All listed values measured at standard atmospheric conditions.
Pneumatic data refer to parallel configuration.

Flow Curves

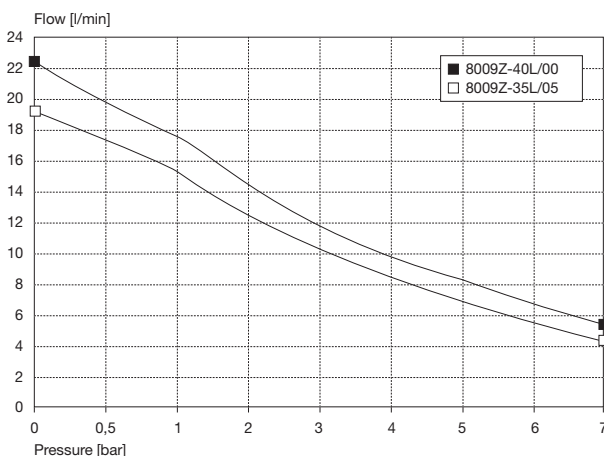

Model key:

Z = Double head
 L = Capacitor motor
 230 V/50 Hz
 Motor type
 8009 Z - 35 L / 05 / AC
 Series Eccentric Spacer plate

8009... Stock programme

Option:
Different heads and outlet connectors

The information presented in this material is based on technical data and test results of nominal units. It is believed to be accurate and reliable and is offered as an aid to help in the selection of Thomas products. It is the responsibility of the user to determine the suitability of the product for the intended use and the user assumes all risk and liability whatsoever in connection therewith. Thomas does not warrant, guarantee or assume any obligation or liability in connection with this information.

THOMAS
by Gardner Denver

Wiring diagram (8003 BLDC)

Pin	Function	Colour	Control
Pin 1	V Supply	Red	12 VDC (max. voltage range: 10..18 VDC) 24 VDC (max. voltage range: 10..28 VDC)
Pin 2	Ground	Black	Ground for Vsupply (PIN 1) and Speed Control (PIN3)
Pin 3	Speed control	White	analog: 0..5 VDC (max. 28V) PWM: 6..20 kHz - 14..96% Speed voltage input threshold: 0,2 V
Pin 4	Tacho out	Green	18 pulses per revolution Pulse time „LOW“: 195 μ s Output level „LOW“: 0 / max. 0,5 V Output level „HIGH“: min. 4 V / max. 5 V

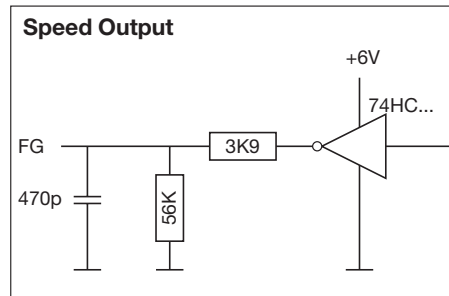
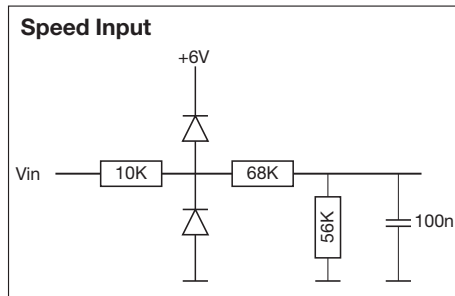

Optional: Adapter for 2-wire duty incl. potentiometer for speed adjustment

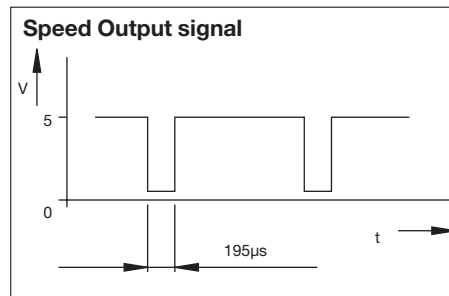

Options / Accessories

P/N 29011930

Adapter for BLDC motor

4-2 wire w/manual speed control
12VDC "red"

P/N 29011931

Adapter for BLDC motor

4-2 wire w/manual speed control
24VDC "black"



Notes



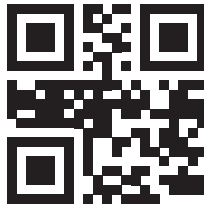

THOMAS
by Gardner Denver

ClimatePartner^o
climate neutral

Print | ID: 53097-1311-1001

Printed in Germany.
Art.-Nr.: 17000058 02/2015